

EN

Corrosion and Sludge Protection  
in Water Recirculation Systems

Heating - Cooling

**ELYSATOR**  
by ELYSATOR™

Installation  
How it works  
Operation  
Service



easy to use, very efficient  
green technology

**ELYSATOR**   
engineering water

[www.elysator.com](http://www.elysator.com)



# Contents

The problem	4
The solution	5
Correct installation	6
Correct installation	7
Data and dimensions	8
Requirements of the water used to fill the appliance	9
Requirements of the system water	9
Operating meter	10
Sludge removal	11
Maintenance	12
Diagnosis	13
Service manual	16

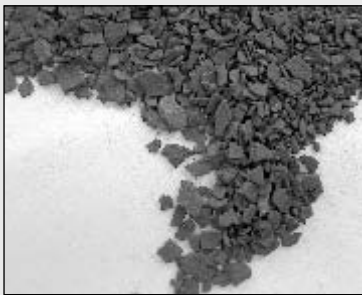

# The problem

Early underfloor heating systems used plastic pipes that were permeable to oxygen. Technology has since advanced to the point where it is now possible to produce underfloor heating pipes that are practically diffusion proof. Valves, threaded joints, circulating pumps, regulators, automatic bleed devices and faulty expansion tanks, however, are still potentially important sources of oxygen uptake. Oxygen diffusing into the heating water, too low a pH value and raised electrical conductivity of the system water can all lead to corrosion and blockage of the heating system from corrosion products. In the past, the most common method of corrosion protection was to add chemical corrosion inhibitors. In ma-

ny cases, however, it was found impossible to provide active protection in cracks or under deposits of dirt or rust, so this approach could not deliver a satisfactory solution to the problem. Furthermore, it is costly and time-consuming to monitor that the correct amounts of inhibitors are added. Using heat exchangers to separate the system into a heating circuit and hot-water circuit ultimately merely splits the problem into two parts without achieving active corrosion protection. Modern heating systems are more sensitive to signs of corrosion, limescale and any other deposits.

- Underfloor heating pipes clogged with corrosion products
- Blockages in control valves and pumps
- Boiler corroded through
- Holes in radiators leading to water damage
- Noisy circulation from gases produced by corrosion
- Increased power consumption from irregular heat distribution

# The solution

A reaction tank containing high-purity magnesium anodes – the ELYSATOR – is installed in a bypass circuit of the heating system. The reaction with the sacrificial metal (magnesium), which goes into solution, reduces the concentration of atmospheric oxygen diffusing into the water to a negligible level. The

magnesium hydroxide produced in this process helps to raise the pH value to an optimum range.

Depending on the composition of the water in the system, its electrical conductivity then drops thanks to partial precipitation which reduces the water hardness. The result is alkaline water that is low in salts

and has a minimum oxygen concentration.

Corrosion damage is unlikely in systems containing water with these properties.

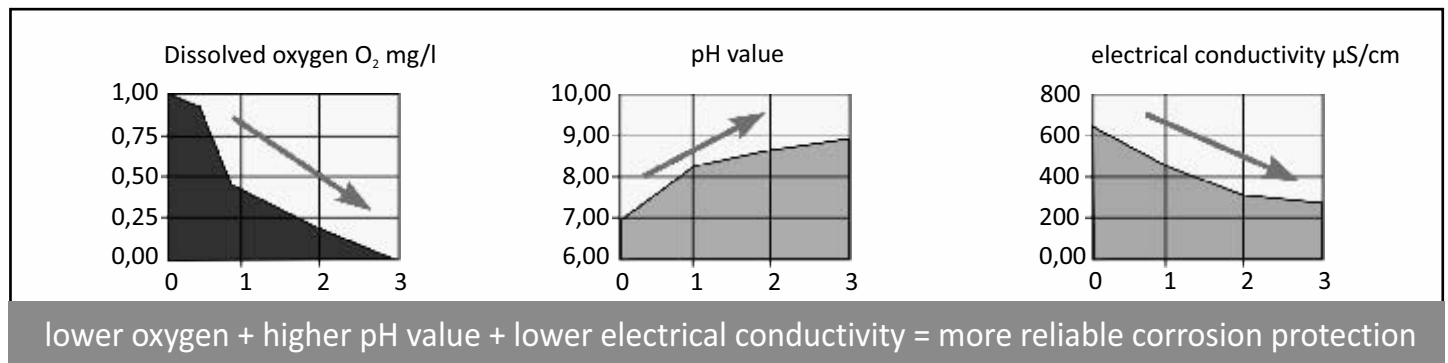

## Block diagram, simplified

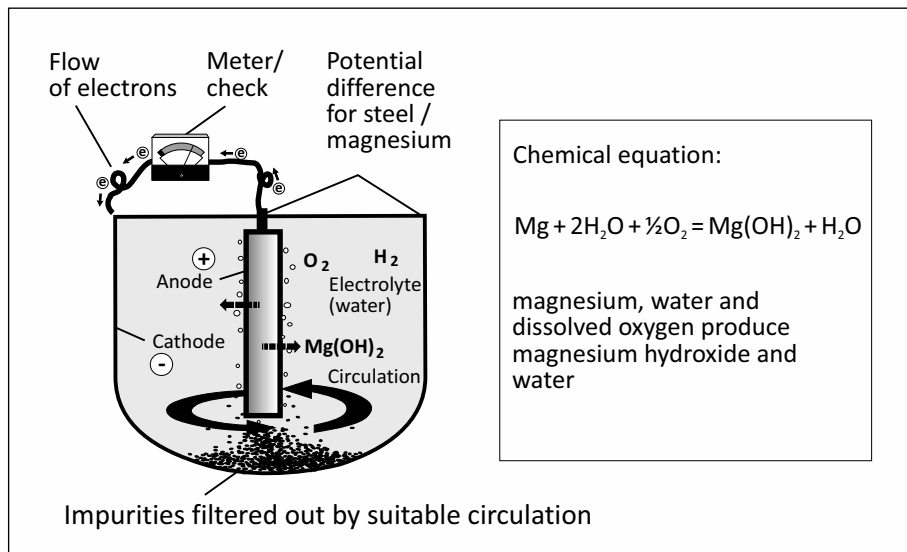

## Operation & Servicing

Corrosion residues that are carried along by the flow of water are deposited in the ELYSATOR for removal as sludge in the restoration phase, until the water is clear. Old systems, however, that are heavily contaminated or treated with chemicals must be flushed through thoroughly before fitting the ELYSATOR (e.g. using SANOL H-15). Subsequent maintenance simply involves changing the anodes

every 3 to 5 years; the ELYSATOR works without an external power supply and without chemical additives. The ELYSATOR is the market leader in this field of corrosion protection, and has been used successfully for over 30 years in heating and cooling systems. The process is equally suited to protecting new installations and restoring existing systems to health.

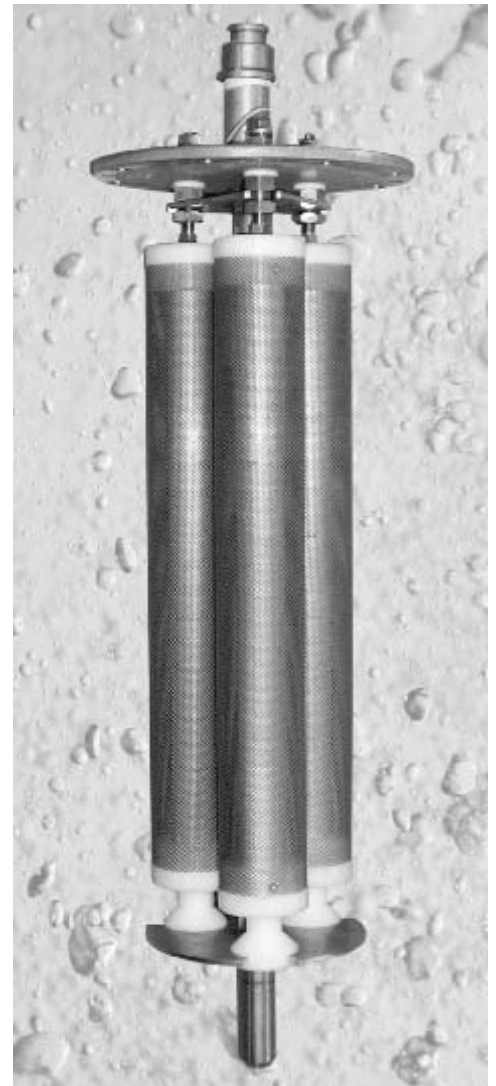

# Installing the ELYSATOR

Where you choose to site the ELYSATOR in your heating system will depend on the following main factors:

- Mixing and distribution of treated water**  
If there are large temperature differences at the mixer valves then only small amounts of water are exchanged. All the water contained in the system should regularly flow through the ELYSATOR however.
- Hydraulic requirements**  
Normally water circulates through the ELYSATOR passively, i.e. without a dedicated pump, driven solely by the pressure difference between flow and return lines. We recommend making the mouth of the supply to the ELYSATOR as large as possible.
- Particle filtration through the bypass circuit**  
The ELYSATOR acts as a gravity filter, removing impurities and particles produced by corrosion. These can only be filtered out, however, if the water flow also carries the particles through the ELYSATOR. This means that the ELYSATOR should be installed in a suitable position in the main circuit using connecting pipes designed to be large enough to allow sludge particles to reach the ELYSATOR in the water flow.
- Installing close to the source of oxygen diffusion**  
If you know the source of oxygen diffusion (e.g. the underfloor heating unit), the ELYSATOR should be located as close as possible to the oxygen source, i.e. within the underfloor heating unit.
- Condensing boilers**  
Connecting the ELYSATOR between the main pipe, flow pipe and return pipe results in a slight rise in the return temperature; this is undesirable in condensing boilers. In this case, the ELYSATOR should be installed only in the return line or only in the flow line. An additional circuit control valve or pump may be needed for this situation.

It is the job of the consultant heating engineer to determine the best installation position. We are happy to provide any advice here.

## Regulating the flow rate

	Typ 50	Typ 75	Typ 100	Typ 260	Typ 500	Typ 800
Connector size	1"	1"	1"	1¼"	1½"	1½"
System Volume m <sup>3</sup>	15.0	25.0	35.0	70	120	220
Litres/minute	5 - 10	8 - 15	10 - 20	25 - 50	50 - 100	80 - 160

The recommended values specify the minimum flow rate for achieving adequate water treatment. A higher flow rate does not hinder the water treatment, but can impair the filtration performance. For pumps with a regulated flow rate, position the ELYSATOR so that the minimum flow rate can be achieved when the pump is running slowly. If the average flow rate does not reach the minimum rate, we recommend installing a small booster pump in the ELYSATOR circuit.

# Installing the ELYSATOR

## Parts included with the ELYSATOR

- 1 ELYSATOR tank
- 2 Duct containing indicator
- 3 Drain
- 4 Air vent
- 5 Flowmeter

## Installation parts provided by customer:

- 6 2 x bracket
- 7 regulator
- 8 2 x stopcock
- 9 screw connection

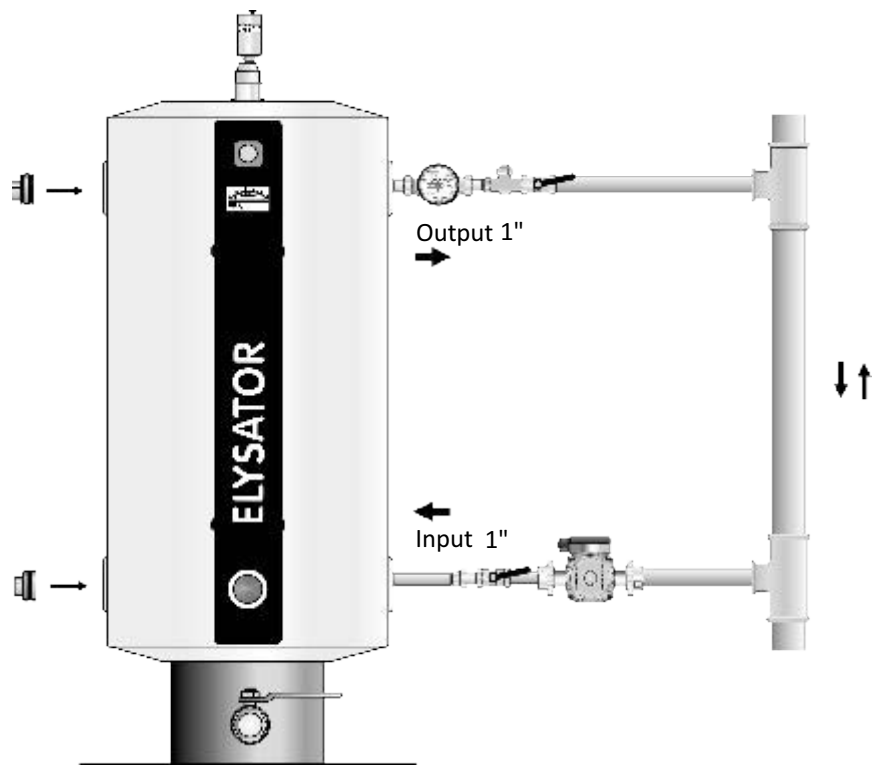
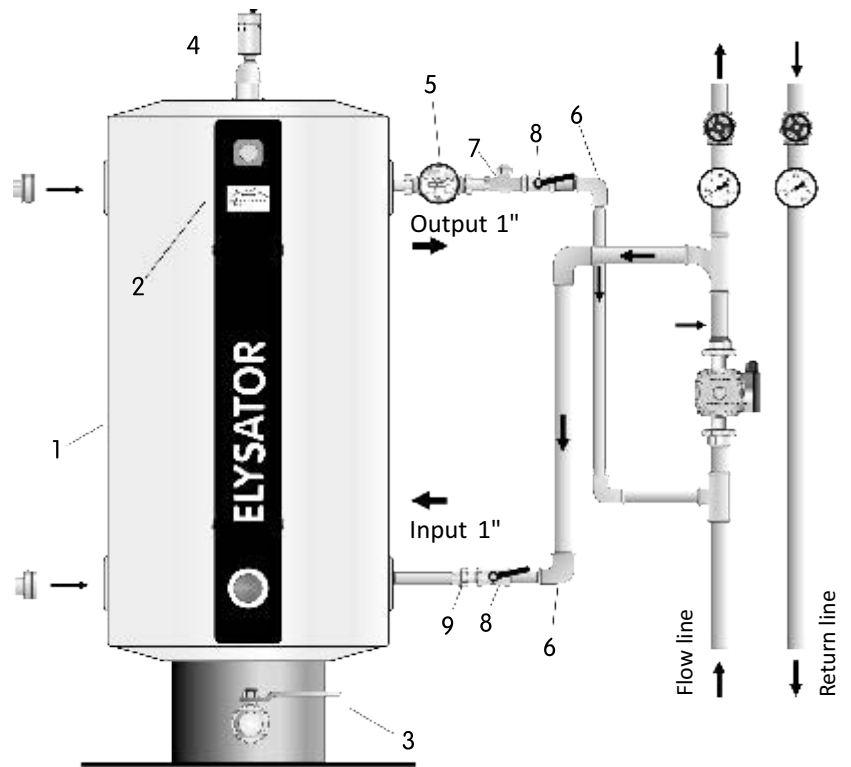



## Technical data

Material of vessel:	Inox CrNiMo 1.4401
Insulation:	Foam with coated metal sheet, CFC-free
Operating pressure:	10 bar
Max. temp.:	100 °C

Dimensions in mm	Typ 50	Typ 75	Typ 100	Typ 260	Typ 500	Typ 800
A Overall height	1045	1045	1045	1590	2230	2120
B Tank diameter	420	420	420	600	600	800
C Inspection hatch	140	140	140	270	230	300
D Inlet - outlet	390	390	390	625	1290	1060
E Inlet - bottom	290	290	290	385	385	530
Connector size	1"	1"	1"	1¼"	1½"	1½"
System Volume m <sup>3</sup>	15.0	25.0	35.0	70	120	220
Litres/minute	5 - 10	8 - 15	10 - 20	25 - 50	50 - 100	80 - 160

The (water) capacity of a heat storage tank, e.g. in solar installations, can be subtracted from the total volume of water to work out the ELYSATOR type required.

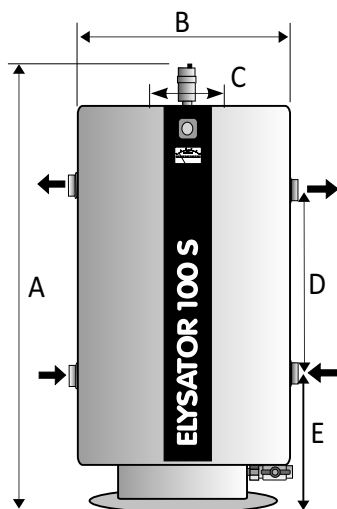

[www.elysator.com](http://www.elysator.com)



## 6 good reasons

- Complete confidence that your heating system will retain its value, whether old or new.
- Quality engineering built upon years of research and development.
- A long-lasting product made to Swiss quality standards from corrosion-proof materials.
- Environmentally friendly technology that works without external power and chemicals
- Self-regulating, low-maintenance operation
- Appliance operation can be metered and monitored.



## Requirements of the water used to fill the appliance

### ✓ **Hard water can cause damage**

The quantity of dissolved calcium carbonate  $\text{CaCO}_3$  (chalk, lime etc.) should not exceed a certain amount per  $\text{m}^3$  of system water, otherwise this may produce limescale deposits that can cause stress fractures in the boiler or blockages in heat exchangers. Particular care is needed in heating systems fitted with high-performance heat exchangers, heat pumps, capillary tube systems (plastic pipes with a small diameter) and heat storage tanks.

If possible always ask your boiler manufacturer or system supplier about the water quality levels for their products. Normally there is no need to treat top-up water. Please note that if claiming for system components under warranty, the requirements stipulated by the relevant manufacturer apply, not our recommendations.

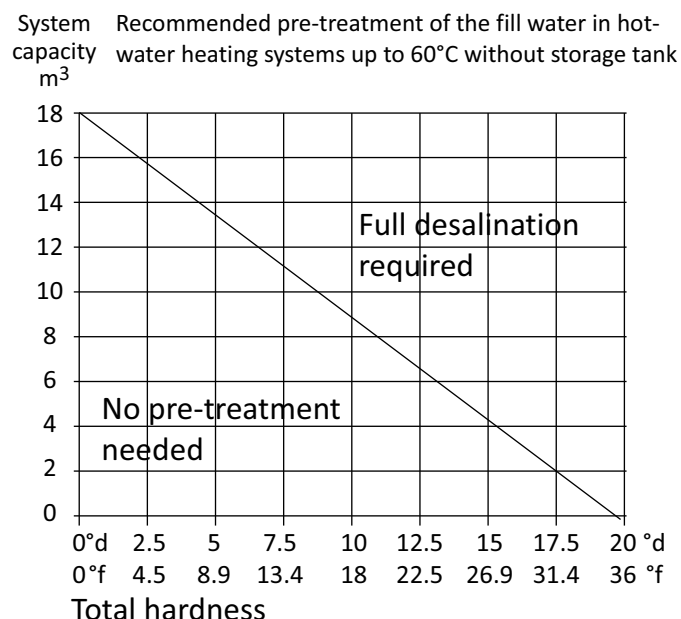

### ✓ **If the water needs pre-treating, use fully desalinated water**

If the hardness of the water means that it must be pre-treated, please do not use a water softener. The ion exchanger in the water softener unit only replaces the calcium and magnesium with sodium. This does not change the overall level of salts in the water, which remains high, resulting in a raised electrical conductivity that promotes corrosion. Fully desalinated water, on the other hand, contains neither encrusting carbonates (limescale) nor materials that encourage corrosion (chlorides, sulphates, nitrates etc.), and has a minimum electrical conductivity. The relatively low pH value of fully desalinated water, however, means that it does have a temporary corrosive effect. We recommend using some form of corrosion inhibitor. Clean rain water has similar properties and can be used in the same way for filling the appliance.

## Requirements of the system water

### ✓ **No chemical additives**

The ELYSATOR corrosion-protection system must not be used in combination with chemical water additives. Corrosion inhibitors can impede the action of the sacrificial anode and create unwanted chemical compounds. If you plan to use an ELYSATOR, the system must be flushed through thoroughly to remove the inhibitors. A cleaning and dispersing agent such as SANOL H-15 is ideal for this purpose.

### ✓ **Flushing through clogged systems**

Systems that have become so clogged with sludge that hydraulic problems have occurred should be flushed through when the ELYSATOR is installed. Corrosion could still occur under deposits despite protective measures, because the water is not being replaced. The boiler must also be flushed at the same time.

# Operating meter

The **ELYSATOR meter** measures the current emitted from the anode as a proportion of the current emitted from the cathode. It is a direct measure of the corrosiveness of the system water. The ELYSATOR system is self regulating. The anode automatically works harder with corrosive water than with water that is no longer reactive, and the needle then shows a stronger deflection on the meter. The operating meter is permanently on. Some appliance models are fitted with a **Test button** for the meter. Pressing the button bypasses the meter and the needle should drop. This is just a check that the needle is not physically stuck. The needle should not drop fully to the left in the test.

The change in the needle position over time also gives an indication of the anode condition. Some examples of this:

- If the meter reads 100% over 1 to 2 years, but suddenly drops to 0%, it is highly likely that the anode is spent (rapid usage)
- If the meter reads 50% over 3 to 6 years, but now reads 0%, it is highly likely that the anode is spent (standard usage)
- If the meter sits at a low reading for more than 6 years, and the needle drops as expected when you press the test button, then the anode is still working even after this long period of time (slow usage)
- If the meter already reads in the red region after just a few weeks, then oxidation of the anode is likely. This should be checked.
- In the summer season the anode reading drops as expected, because there is no circulation through the ELYSATOR.

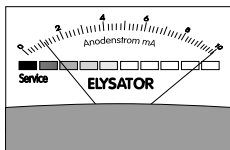

## The needle swing lies between 10% and 100%

This is the normal operating region. The lower the reading, the less the anode needs to work.

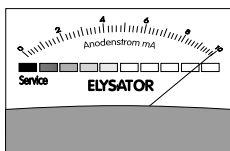

## The needle always reads 100%

The anode is working hard. If the needle remains in this position for longer than one heating season, the ELYSATOR may not be big enough or the water may contain too many corrosive substances.

Action: Analyse the heating water, talk to your heating adviser

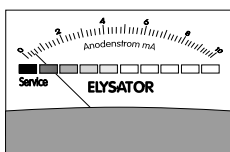

**The needle lies continuously close to the red region;** the needle still drops to the minimum reading when you press the test button however. The anode no longer needs to work because the chemical reactions in the water have finished, or the anode can no longer work because it is coated in a barrier layer.

Action: Remove the sludge from the ELYSATOR and fill with fresh water. Keep the stopcocks closed for a day to hold the more corrosive fresh water inside the ELYSATOR. After a day, if the operating meter shows a higher reading, everything is OK and the ELYSATOR can be put back into operation. Otherwise you need to open the hatch to inspect the appliance.

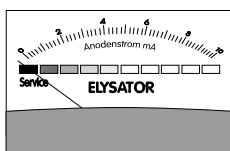

## The needle drops into the red region within a few weeks

The anode is spent or coated in a barrier layer.

Action: Open up the appliance and clean or replace the anode.

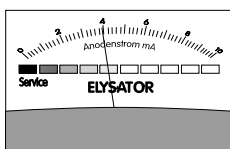

**The meter continues to show an absolutely constant reading over a long period**  
The operating meter might be faulty.

Action: On appliances fitted with a test button, press the button to check the meter (needle should drop to the left). On appliances without a test button, desludge the ELYSATOR, fill with fresh water (keep stopcocks closed) and after 1 day check the meter for any change.

**If there is no change in the needle position, the meter is probably faulty.**

# Sludge removal

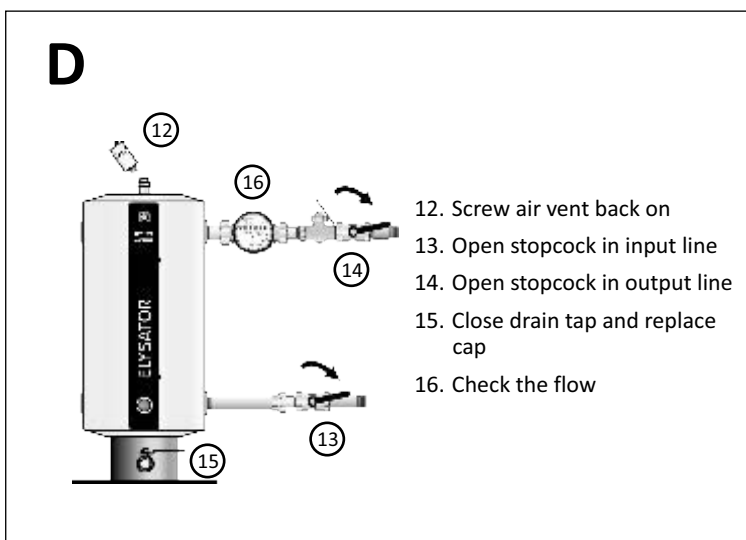
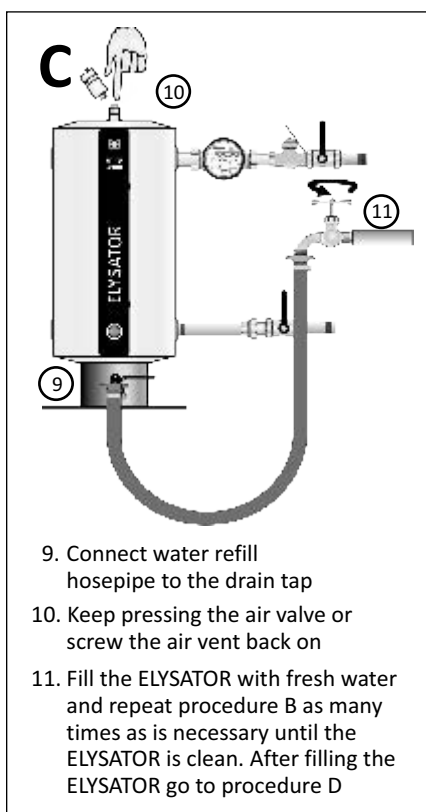
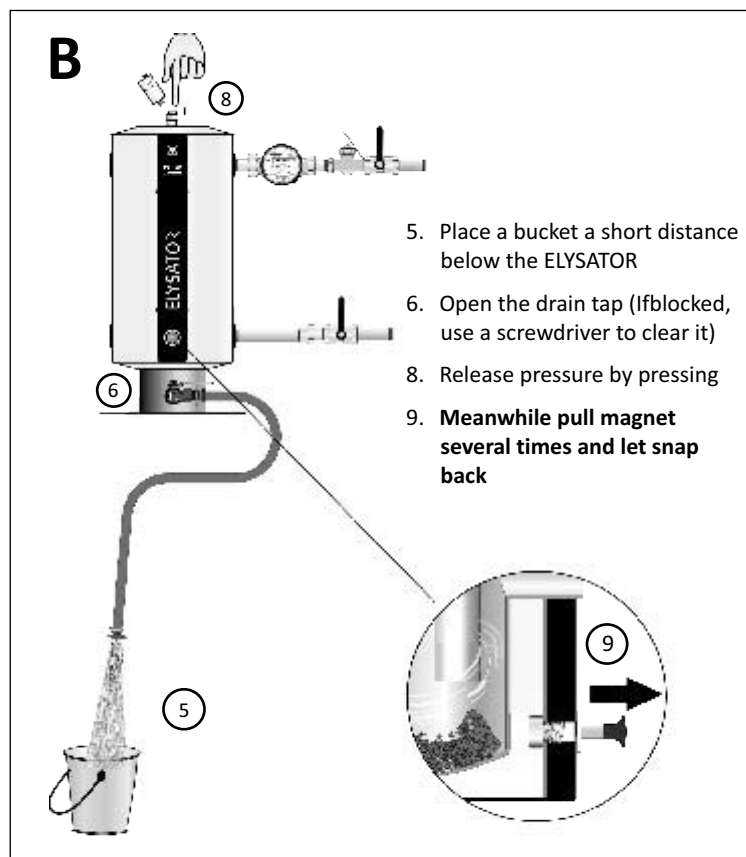
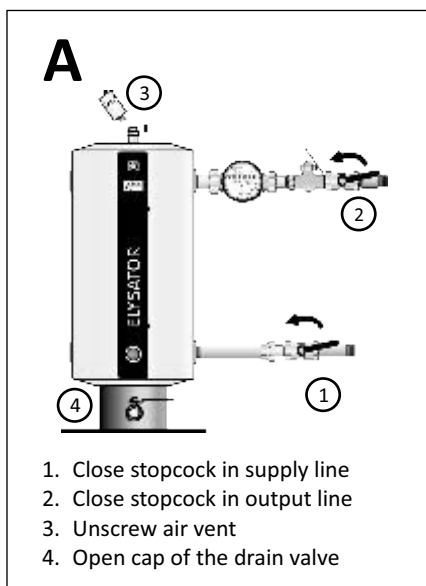

## How often should sludge be removed?

Corrosion residues that are carried along by the flow of water are deposited in the ELYSATOR for removal as sludge in the restoration phase. Nevertheless, heavily clogged heating systems and those containing chemical additives must be cleaned thoroughly before installing the ELYSATOR. Note that fresh water contains about 100 times more oxygen than is allowed in the heating system for operation. It is not advisable to remove the sludge too frequently because this increases oxygen corrosion. If, however, you wait too long before removing sludge from the ELYSATOR, it fills up with sludge and can sustain damage itself. So check the amount of accumulating sludge and adjust the sludge-removal interval accordingly. Do not de-sludge the appliance more than twice in a heating season or less than once every two years. There are various ways of removing sludge from the appliance. The method described above is reliable, simple and introduces only a small amount of fresh water into the system.

# Appliance service

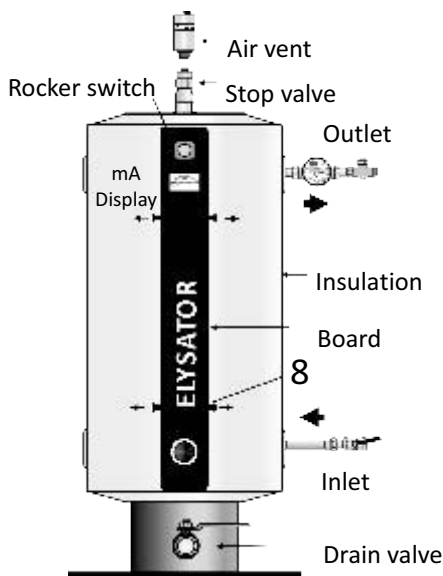

## Replacing the air vent and stop valve

- Close the stopcocks in the input and output lines to the ELYSATOR
- Unscrew air vent
- Partially empty the ELYSATOR (release the vacuum by pressing the spring in the stop valve)
- Unscrew stop valve
- Pack thread on new stop valve with hemp and screw back in; screw in air vent
- Fill ELYSATOR with water via the drain; Open the input/output lines

## Replacing the meter and rocker switch

- Unscrew self-tapping screws **1**, remove flange plate
- Remove connector **3** from the blade terminal and remove the screw **4** from the meter and flange
- Unscrew screws **8**, remove duct
- Replace meter or rocker switch
- Reassemble appliance in reverse order

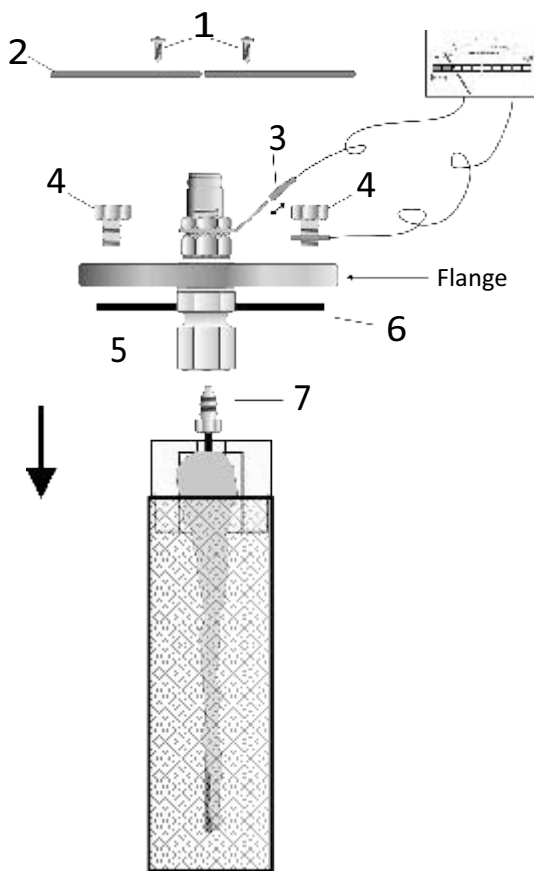

Magnesium anode

## Opening the appliance and inspecting the anode

If the needle on the meter lies right in the red «Service» region while the heating is running, the anode must be checked.

- Close the input and output lines to the ELYSATOR
- Unscrew the air vent and release the vacuum by pressing the spring in the stop valve; let the water drain out
- Unscrew self-tapping screws **1**, remove flange plate **2**
- Remove connector **3** from the blade terminal and remove the screws **4** from the meter and flange
- Now remove the entire flange including anode holder.

## Fitting a new anode:

- The anode is screwed internally onto a cone screw and fastened by an insulating locknut. Use an SW17 spanner to hold this insulating nut **5**. Unscrew the cone screw **7**, SW 10 together with the anode core.
- Then screw in the new anode in the same way and tighten. This assembly creates a ring contact between the anode and the screw connection.
- After assembling the anode, check the insulating screw **5** and tighten slightly if necessary.
- Make sure that the contact blades are fitted carefully and firmly. Contacts must be perfect to guarantee operation of the ELYSATOR.

# Diagnostic help

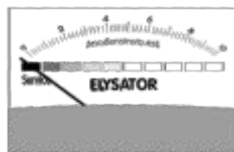

## The operating meter lies in the red region

The rate at which the appliance works is self-regulating according to the water quality. The question here is whether the anode does not need to work or whether it cannot work at the moment. De-sludge the ELYSATOR as specified in the instructions, fill with fresh water and leave the stopcocks closed. Fresh water is corrosive; if the operating meter indicates that the anode is not working after 1 to 2 days, the appliance must be opened for servicing.

If after servicing the appliance there is still no indication of it working, there may be a short-circuit between anode and flange; check the electrically insulated flange grommet (insulating screw).



## The test button does not work

Not all appliances have a test button. The sole purpose of the button is to make sure that the meter needle is not stuck in its position. The needle should move when the button is pressed. The button bypasses the instrument but does not disconnect it. If the contacts are slightly oxidised, the needle may not drop right back to zero; this is not a problem and does not impair operation of the ELYSATOR.



## The water-meter reading is not increasing

The question here is whether there is no water flow or whether the meter is faulty. Check the temperature of the connecting pipes to the ELYSATOR. If the heating is running but the pipes are cold, then circulation to the ELYSATOR has stopped. Check all the stopcocks in the connecting pipes to the ELYSATOR. Open the throttle/regulating valve in the connecting pipe; you might be able to release a blockage in this way. If the pipes are warm but the water-meter reading is not changing, then it is likely that the meter is blocked or faulty.



## The ELYSATOR is leaking

Always check the air-vent valve first because even if the ELYSATOR is dripping from below, this is often caused by a leaking air-vent valve where the water runs down under the insulation. Disconnect the appliance by switching off the stopcocks in the input and output lines to the ELYSATOR and contact your heating installer.



## Corrosion/sludge blockages despite ELYSATOR

First check whether there is adequate water circulation through the ELYSATOR and that the meter shows it is working properly. Check whether the appliance is installed correctly and in a position where it can work efficiently. Does the quality of the water used to fill the appliance comply with requirements? Contact your ELYSATOR consultant and ask them to examine the system water to clarify the situation further.





# Service Journal

Installer: \_\_\_\_\_

\_\_\_\_\_

\_\_\_\_\_

Project: \_\_\_\_\_

\_\_\_\_\_

\_\_\_\_\_

Date of installation: \_\_\_\_\_

Device N<sup>o</sup>. \_\_\_\_\_

Drain interval:

Service interval:

Date	Job	Watermeter m <sup>3</sup>	mA	Company/Sign